

DavidsonSensors™

Fiber Optic Cable and Transmission Standard

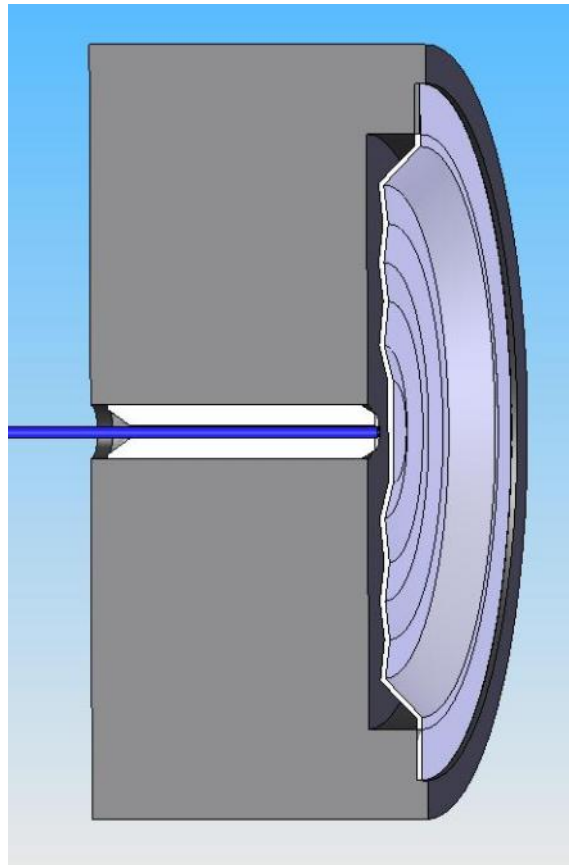

Davidson Fiber Optic Sensing System

- DavidsonSensors™ Measure Temperature, Pressure, Vacuum, Flow, Level, and Vibration
- DavidsonSensors™ Transmit Intrinsically Safe Signals to Passive Fiber Optic Transducers
- DavidsonSensors™ are Immune to Lightning Damage and Grounding Problems
- DavidsonSensors™ are Immune to Electromagnetic and Radio Frequency Interference (EMI/RFI)
- DavidsonSensors™ Operate at 1000°F
- DavidsonSensors™ are Easy to Install and Require Very Low Maintenance

Davidson Fiber Optic Cable and Transmission Standard

1. Introduction

Fiber optic sensing technology offers a number of advantages for measurement in harsh industrial environments. Fiber optic transducers are tolerant to high temperatures, intrinsically safe, and immune to electromagnetic interference. Since many fiber optic transducers can be multiplexed with a single signal conditioner, significant cost savings can be achieved. To realize the full potential of this technology, the signal conditioner and transducer must be connected to one another with a fiber optic cable.

This guide is intended to help the industrial user specify the appropriate fiber optic cable and provide instructions for routing the cable for use with Davidson fiber optic transducers and signal conditioners. Note for special applications involving downhole pressure measurement or sensing applications in environments with high levels of radiation or high concentrations of hydrogen, call Davidson and discuss your specific needs with an applications engineer.

For more advanced information to help with the planning of a fiber optic sensing system, see the Davidson Guide to Configuring a Fiber Optic Sensing System which is available at www.davidson-instruments.com. For more detailed technical information about fiber optic sensing systems, see Davidson technical publications at www.davidson-instruments.com/techpubs.html.

2. Safety

Davidson has designed its systems for industrial applications. The systems are eye-safe and intrinsically-safe. DavidsonSensors™ use broadband white light from tungsten lamps and narrow-band LEDs as the light sources. The amount of light energy transmitted into an optical fiber is not sufficient to cause damage to the eye and is not sufficient for ignition. The maximum energy transmitted in a fiber is below the standards set by ANSI/ISA-TR12.21.01-2004, Use of Fiber Optic Systems in Class I Hazardous (Classified) Locations.

- **Regardless of the energy level being transmitted in an optical fiber, never look directly into an optical fiber that is transmitting light.**
- **Not all fiber optic systems use safe levels of white light and serious damage could occur from looking into fibers connected to systems that use invisible light, (i.e. light at wavelengths longer than 700 nm).**
- **The human eye is not a good indicator of light intensity and has quite different sensitivity than the detectors used to measure the light level. A light meter is the proper instrument for measuring light intensity.**

DAVIDSON

INSTRUMENTS

- **Glass fibers and fiber optic cables should never be placed near the eye because of the physical danger and potential consequences of getting a glass fiber in the eye.**

Proper test equipment and personal safety gear should be used by trained personnel when performing optical circuit diagnostics.

3. Fiber Optic Cable Specifications

Fiber optic sensors use optical fiber and light to make measurements of temperature, pressure, and other physical parameters. Optical fibers are strands of glass that transmit light over long distances and are the equivalent of wire in electronic systems. The glass optical fibers are 0.005 inch in diameter and are protected from damage by acrylate, polyimide, polyethylene, or metal coatings. The individual fibers are often combined with Kevlar or other strengthening and jacketing materials to form a fiber optic cable.

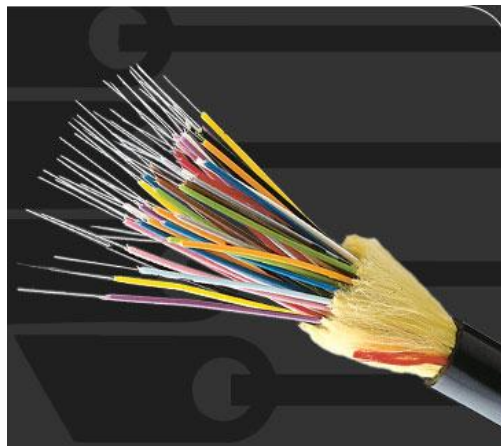

Figure 1 – Multi-strand Fiber Optic Cable from Optical Cable Corporation

- 3.1 Optical Fiber Specifications** – Although fiber optic cable from different vendors is interchangeable, the specifications for the optical fiber must match those used in the transducers and signal conditioners. If the optical fiber specifications do not match, severe degradation in the system performance will occur. The fiber optic cable used for most telecommunications systems is not appropriate for Davidson fiber optic sensing systems. Any fiber optic cable used with DavidsonSensors™ should meet the following specifications:

Core	62.5 um
Clad	125 um
Index	Graded
Numerical Aperture	> .25

- 3.2. Cable Types** – Optical fibers can be packaged in a variety of ways to create a cable. There are basically two types of cables, loose-tube cable and tight buffered cable. For most industrial applications, Davidson recommends the use of tight buffered cables.

Tight buffer cable is used when the fiber count is low and for aerial installations. Tight-buffered cables have a buffer in tight contact with the fiber. The tight buffer makes large fiber count cables very stiff so their practical use is limited to fiber counts of less than fifty. The tight-buffered design provides a rugged cable structure to protect individual fibers during handling and routing.

Loose tube cable is used for cables with high fiber count and for applications that require buried cable. Loose-tube cables typically hold up to 12 fibers per buffer tube with a total fiber count exceeding 200 fibers per cable. Color-coded plastic buffer tubes house and protect optical fibers. A gel compound in the cable impedes water penetration. Buffer tubes are wrapped around a dielectric or steel central member, which serves as an anti-buckling element.

- 3.3 Cable Temperature Rating** – Davidson recommends use of cable from the Optical Cable Corporation (OCC) for most industrial applications. OCC's DX-series distribution cable in applications where the cable is exposed to temperatures ranging from -40° F to 185° F and OCC's D-series military-grade distribution cable when the cable is exposed to temperatures ranging from -67° F to 185° F. Davidson temperature tolerant cable is suitable for use at temperatures up to 550°F. Other special cables can be manufactured by Davidson for use at temperatures up to 1000°F. See fiber optic cable suppliers identified in Section 7 for details about the temperature rating of fiber optic cables.

OCC DX-series distribution cable	-40° F to 185° F
OCC D-series military-grade distribution cable	-67° F to 185° F
Davidson high temperature cable	-40° F to 550° F
Davidson ultra-high temperature cable	-40° F to 1000° F

- 3.4 Jacketing of the Cable** – Commercial suppliers of fiber optic cable offer a host of cable packaging and mechanical protection options. Davidson recommends the use of stainless steel armor for cables that may be subject to mechanical damage. Davidson offers two types of armor protection, stainless steel Teflon overbraid for basic protection and stainless steel corrugated sleeving for maximum protection.
- 3.5 Multiplexing of Transducers** – Davidson discrete fiber optic sensing systems require a dedicated optical fiber for each sensor. Large numbers of optical fibers can be packaged in a single small diameter home run cable to provide effective multiplexing of many transducers with a single signal conditioner.

- 3.6 Multi-strand Cables** – Cables are readily available with 1, 2, 8, 12, 18, 36, and 48 strands of optical fiber. Each segment in the optical circuit may require different numbers of optical fibers to complete the circuit. The schematic of the plan should define the number of fibers in each segment of the optical circuit. See [Davidson Guide to Configuring a Fiber Optic Sensing System](#) (available at www.davidson-instruments.com) for help in planning your installation.

4. Fiber Optic Cable Runs

For optimal system performance in most applications, the total transmission distance (total length of the cable run) from the signal conditioner to transducer should be limited to 1000 feet.

DavidsonSystems™ can work at ranges greater than 1000 feet with some degradation of signal quality due to slight changes in the spectral content of the light. When the length of the cable run is uncertain, it is best to order enough fiber to assure enough slack to allow efficient field termination.

- 4.1 Location of Junctions / Terminations** – For optimal system performance, it is best to minimize the number of junctions / terminations in the fiber optic circuit and to plan the location of junction boxes in areas convenient for installation technicians to make the necessary terminations. The optical fibers must be properly terminated at every junction to complete the optical circuit. Typical junctions include the terminations between the following:

- Fiber optic cable and transducer
- Fiber optic cable and signal conditioner
- Mating optical fibers at each junction box

- 4.2 Slack Fiber at the Junction Box** – The circuit designer should allow four feet of slack fiber at each junction box to facilitate the proper termination and to enable proper strain relief of the fiber optic cable.

- 4.3 Fiber Optic Terminations** – Ideally, all terminations made at junction boxes will be permanent fusion splices. Mechanical connections should be limited to use in those situations where periodic connect and disconnect is required. Mechanical connections are not a good substitute for permanent fusion splices in mission critical or hazardous field conditions. Davidson uses the most rugged and dependable connectors available but even these connectors are not as good as a permanent fusion splice connection. The standards of acceptable quality of the connectors and terminations for fiber optic sensing systems exceed the standards for digital signal quality required in telecommunication systems. When making a mechanical connection, it is important that the termination be made and inspected in compliance with Davidson termination standards. Severe degradation will result from poor terminations and poor weather seals. For more detail on this subject, see [Davidson Fiber Optic Termination Standards](#) available at www.davidson-instruments.com/techpubs.html).

DAVIDSON

INSTRUMENTS

- 4.4 Fiber Optic Tie-downs** – Fiber optic cables should be free of vibration and should be tied down to prevent severe vibration of the fiber optic cable. The cable should not be pinched or crimped when making tie downs.
- 4.5 Color Code and Labels** – Most fiber optic cable is color-coded. Like any complex circuit, it is wise to develop a color-code and labeling scheme to make installation and diagnostics effective. Davidson has standardized its transducer color-code using blue for pressure (primary measurement) and orange for temperature (secondary measurement) whenever a duplex transducer is manufactured.
- 4.6 Pulling Force** – Most commercial fiber optic cables can withstand a large tensile force, however, individual fibers can be broken if they are subjected to severe tensile loads. It is important to check the cable specifications to assure that tensile load specifications are not exceeded during installation.
- 4.7 Bend Radius** – Bending of an optical fiber causes light losses and could result in a total loss of signal under extreme conditions. Most fiber optic cable can tolerate a bend radius of 15X the cable diameter during installation. It is important to check the cable specifications to assure the minimum bend radius specifications are not exceeded during installation.
- 4.8 Conduit and Cable Trays** – Fiber optic cables are rugged but it is good practice to route the fiber optic cable through existing conduit and cable trays when they are available.

5. Diagnostics Testing of the Optical Circuit

Before a circuit is completed, it is good practice to test the optical circuit for continuity and losses and to document those test results. Installation of a quality optical circuit will simplify installation and commissioning of the fiber optic sensing system.

- 5.1 Transmission Test** – This test is appropriate whenever one or both ends are to be fusion spliced.
- 5.2 Reflectance Test** – This test is appropriate whenever there is a mechanical connector in the optical circuit.
- 5.3 Inspection of Terminations** – Each mechanical connector should be visually examined using a 400X microscope and an interferometer. Ideally, a photographic image and an interferogram image of each connector are obtained as well to verify quality. For more information on the standards of quality for mechanical connectors, see [Davidson Fiber Optic Termination Standard](http://www.davidson-instruments.com/techpubs.html) available at www.davidson-instruments.com/techpubs.html.

DAVIDSON

INSTRUMENTS

Fiber Optic Cable and Transmission Standard

6. Troubleshooting the Optical Circuit

The following is intended to provide some insight regarding the likely cause of a problem in an optical circuit:

Problem	No Light	High Losses in Transmission	High Losses in Reflection	False Signals
Possible Fault				
Incomplete Optical Circuit	X			
Broken Optical Fiber	X			X
Mislabeled Optical Fiber	X			
Poor Fusion Splice		X	X	X
Poor Polish on Connectors		X	X	X
Dirty Connectors	X	X	X	X
Too Many Connectors		X	X	X
Strain on Connector		X	X	X
Vibrating Cable		X	X	X
Crimped Cable		X	X	
Tight Bend Radius		X	X	
Long Transmission Distance		X	X	

7. Sources for Fiber Optic Cable

Any fiber optic cable that meets the optical fiber specification in 3.1 is acceptable. Davidson has purchased fiber optic cable from the following sources:

Optical Cable Corporation

www.occfiber.com

Corning Cable Systems

www.corningcablesystems.com